

INVITATION TO BID

STATE OF ALABAMA

COUNTY OF BALDWIN

NOTICE IS HEREBY GIVEN that the County Commission of Baldwin County, Alabama, will receive bids in the Purchasing Office on November 13, 2025, at 1:30 P.M., for the Purchase of Twenty (20) or More 2025+ Chevrolet Tahoe AnyGlide Rear Storage Boxes with Lower Command Centers or Equivalent for the Baldwin County Sheriff's Office. Bids will be opened on November 13, 2025, at 2:00 P.M., in the Purchasing Conference Room located in the Annex III Building at 257 Hand Ave., Bay Minette, Alabama. Bids received after the November 13, 2025, at 1:30 P.M., deadline will not be considered. All times to be determined solely by the clock on the wall of Purchasing Conference Room. For all purposes and uses herein, a bid and all required paperwork is "received" at the time and date indicated on the Purchasing Office file stamp which shall be impressed on the face of all such documents when and as presented at the Purchasing Office.

SEE ATTACHED SPECIFICATIONS

This invitation package consists of NINE (9) pages. Bidders shall verify they have received all pages as indicated. If all pages have not been received, then it is the responsibility of the bidder to contact the Purchasing Director, Wanda Gautney at (251) 580-2520 phone, (251) 580-2536 fax.

GENERAL BID INFORMATION

Bidders shall carefully read all parts of the invitation package with its accompanying schedules and attachments, if any. Bidders shall direct all requests for explanation or additional information concerning the meaning or interpretation of the conditions or attached specifications of this invitation to Wanda Gautney in writing or e-mail (wgautney@baldwincountyal.gov) in sufficient time for a reply before submission date of bids. The Commission cannot, and does not, guarantee that such inquiries sent by mail or e-mail will be received timely or prior to the required submission date and time. It is the responsibility of the bidder to contact the Purchasing Director, Wanda Gautney, at (251) 580-2520 if a reply is not received.

The use of specific names and numbers in the specifications is not intended to restrict the bidder or any seller or manufacturer but is solely for the purpose of indicating the type, size and quality of materials, product services, or equipment considered best suited for Baldwin County.

Contact initiated by a potential bidder with a county official will be only as specifically set out in this invitation. Any other contact with a county official initiated by a potential bidder or bidder regarding this bid, **between the date of this invitation to the date of bid award**, shall be deemed and treated as an attempt to unduly influence the bid award, and may be grounds for

rejection of the bid submitted by the bidder initiating such other contact, at the discretion of the Baldwin County Commission.

BIDDER QUALIFICATIONS

All bidders, to the best of their knowledge and belief, must be in, and remain in compliance with all applicable Federal, Alabama State, County and municipal laws, regulations, resolutions and ordinances. In particular, and without limitation, all bidders must be licensed and permitted in accordance with The Code of Alabama Title 10, concerning corporations doing business within Alabama, Title 34, dealing with licensing for businesses, Title 40, concerning licenses and taxation, unless otherwise exempt. All bidders should be prepared to submit to the County non-confidential evidence or documentation demonstrating that the fact they are presently licensed and permitted under Alabama law. Such non-confidential evidence or documentation is encouraged to be submitted with the Bid Package.

The bidder expressly acknowledges, to and for the benefit of the Baldwin County Commission, that this Agreement may be funded with **federal grant monies** and, therefore, bidder expressly warrants and agrees that it shall at all times comply with all applicable federal, state, local and municipal laws and regulations. For more information about the Federal regulations visit the website <https://www.ecfr.gov/current/title-2/subtitle-A/chapter-II/part-200> Code of Federal Regulations.

All bidders must provide proof of proper certification of authority, and any required registration, to transact business in this State, in order to perform work for the Baldwin County Commission. Bidder's Registration Number shall be provided on the Bid Response Form. The phone number for the Alabama Secretary of State is (334) 242-5324, Corporate Division.

All vendors, contractors and grantees are required to comply with the Alabama Immigration Law under Sections 31-13-9 (a) and (b) of the Code of Alabama. Forms and documents will be included with award documents. Information and forms can be found on the Baldwin County Commission's Purchasing website under E-Verify at www.baldwincountyal.gov. Please complete and submit with your Bid Response the E-Verify package.

PREPARING THE BID

Bids must be typed or handwritten in ink. A bid submitted in pencil is unacceptable. The Bid Guarantee and Bid Response Form must be the original paperwork; copies are not acceptable. All required paperwork must be received in the sealed Bid Package.

These specifications exhibit the general intent and purpose of Baldwin County regarding this bid; and they shall be so considered by the bidders. Accordingly, the bidder admits and agrees that said specifications are not complete in every detail. The bidder also agrees that the work and materials not indicated, or expressly mentioned in these specifications, but which are reasonably necessary for the full and faithful performance of the item(s) bid in accordance with

the full and faithful intent, will be included in the bid and incorporated in the work the same as if fully and expressly indicated and specified.

The Bidders shall list on a separate sheet of paper any variations from, or exceptions to, the conditions and specifications of this bid. The exceptions shall be labeled “**EXCEPTION(S) TO BID CONDITIONS AND SPECIFICATIONS,**” and shall be attached to the front of the bid inside the Bid Package. Additional features and/or capabilities not included in the specifications may be included in the bid.

To facilitate the bid evaluation and tabulation, bids should be submitted with specifications identified in the order in which they appear in this document. If applicable, the bidder will provide cost in two (2) categories:

(1) Cost using material as specified.

(2) Cost using material as specified of at least 25% recycled material, if available.

It is the intent of the Commission to award bids which include recycled material when not prohibitive in cost and when in compliance with all other terms and conditions of the Alabama Competitive Bid Law.

SUBMITTING THE BID

In the event that a bidder is financing the product(s) through another agency other than itself, the financing agency must sign the Bid Response Form along with the bidder. A copy of the financing agreement and all conditions must be included with the Bid Response Form. The bidder and the Financing Agency will be held to the requirements stated in the Invitation to Bid. Any assignment of the financing agreement must be approved by the financing agency and the County Commission. Failure to disclose the financing information and all conditions will disqualify the Bidder at the County’s discretion.

Bidders that are returning a **NO BID** statement shall write on the outside of the Bid Package, the **Bid Number (i.e. WG26-05) with “NO BID”** written underneath. The Bid Package will not be opened in public, but it will be noted that the bidder did respond.

Bids may be hand delivered at any time prior to the bid opening date and time to the Baldwin County Purchasing Office, Annex III Building, 257 Hand Avenue, ATTN.: Wanda Gautney, **(mailing) 312 Courthouse Square-Suite 15, Bay Minette, Alabama 36507**. The Commission cannot guarantee that bids sent by mail or courier will be received on or before the bid opening day and time as required. Bids received after the deadline shall not be accepted and shall be returned.

All bids received must be in a sealed envelope plainly marked, “**WG26-05**” “**PURCHASE OF TWENTY (20) OR MORE 2025+ CHEVROLET TAHOE ANYGLIDE REAR STORAGE BOXES WITH LOWER COMMAND CENTERS OR EQUIVALENT.**” Bids submitted by “Express/Overnight” services must be in a separate inner envelope/package sealed and identified as stated in the previous sentence. Bidders and any other interested individuals are invited to attend the bid opening.

BID AWARD

All factors stated in this invitation package will be considered in determining the successful bidder, and any omission(s) of the stated requirements may be cause for rejection of the bid (s), all as determined solely by the Baldwin County Commission.

The County Commission reserves the right to study bids as to their correctness and may award the bid within a thirty (30) day period, but the County Commission reserves the right to extend the bid award for an additional thirty (30) days until an award decision can be made.

The Baldwin County Commission reserves the right to reject any, and all bids, to waive any informality in bids, and to accept in whole or in part, such bid or bids, solely at its discretion.

TITLE 39/CODE OF AL COMPLIANCE

As a condition of any Bid Award and the respective contract(s) pursuant thereto, the County places full reliance upon the fact that it is the sole responsibility of any contractor, person or entity entering into such a contract with Baldwin County for the prosecution of any public works, to ensure that they and/or any of their respective agents comply with all applicable provisions of Title 39-1-1 et seq. Code of AL 1975.

More specifically, any contractor, person or entity entering into such a contract with Baldwin County for the prosecution of any public works shall be in compliance with, and have full knowledge of, the following provisions of Title 39:

“(f) The Contractor shall, immediately after the completion of the contract give notice of the completion by an advertisement in a newspaper of general circulation published within the city or county in which the work has been done, for a period of four successive weeks. A final settlement shall not be made upon the contract until the

expiration of 30 days after the completion of the notice. Proof of publication of the notice shall be made by the contractor to the authority by whom the contract was made by affidavit of the publisher and a printed copy of the notice published . . .” §39-1-1(f) Code of AL 1975.

“(g) Subsection (f) shall not apply to contractors performing contracts of less than fifty thousand (\$50,000) in amount. In such cases, the governing body of the contracting agency, to expedite final payment, shall cause notice of final completion of the contract to be published one time in a newspaper of general circulation, published in the county of the contracting agency and shall post notice of final completion on the agency’s bulletin board for one week, and shall require the contractor to certify under oath that all bills have been paid in full. Final settlement with the contractor may be

made at any time after the notice has been posted for one entire week.” §39-1-1
(g) Code of AL 1975.

NOTE: Any failure to fully comply with this section or any applicable laws of the State of Alabama shall be deemed a material breach of the terms of both the Bid Award and the respective contracts resulting there from. Furthermore, Baldwin County takes no responsibility for resulting delayed payments, penalties, or damages as a result of any failure to strictly comply with Alabama Law.

Done this 22nd day of October 2025.



ROGER H. RENDLEMAN, County Administrator
Baldwin County Commission

Bid #WG26-05 Specifications

These specifications shall be construed as minimum. Should manufacturer’s published data or specifications exceed these, such standards shall be considered minimum and furnished. All integral parts not specifically mentioned in the scope of these specifications that are necessary to provide a complete working unit shall be furnished.

Bidder shall give a unit price as indicated on the Bid Response Form. The price shall include all applicable charges, to include but not limited to delivery, etc.

The use of specific names and numbers in the specifications is not intended to restrict the bidder or any seller or manufacturer’s but is solely for the purpose of indicating the type, size and quality of equipment considered best adapted to Baldwin County.

Award will be to the lowest responsible bidder meeting specifications. It is not the policy of the Baldwin County Commission to purchase on the basis of low bid only. Quality, conformity with specifications, purchase for which required, terms of delivery, finance package, resale value of equipment, and fast service and experience are among the factors that will be considered in determining the responsive bidder.

BID RESPONSE FORM

Each supplier should use the Response Form provided for their bid. **Exceptions are to be attached to the back of the Response Form.** The Bid Guarantee should be attached to the front of the Response Form.

DELIVERY

Delivery shall be as soon as possible but not more than SIXTY (60) days after receipt of order from the Baldwin County Commission. **Delivery location shall be the Baldwin County Sheriff’s Office located at 18185 Raymond Fell Drive, Robertsedale, Alabama 36567.** A Purchase Order will be issued for the equipment listed.

SPECIFICATIONS FOR PURCHASE OF TWENTY (20) OR MORE 2025+ CHEVROLET TAHOE ANYGLIDE REAR STORAGE BOXES WITH LOWER COMMAND CENTER OR EQUIVALENT

Rear Cargo Storage Box with Electronics Tray for 2025+ Chevrolet Tahoe

Anyglide SKU 1000: Specs for Tahoe Lower Command Center

- Lower command Width 40.2”
- Lower command Length 40.5”
- Removable Storage Tray Width 37.10
- Removable Storage Tray Length 13.0
- Removable Storage Tray Depth 5.13”

AnyGlide SKU 1000: Tahoe Lower Command Center

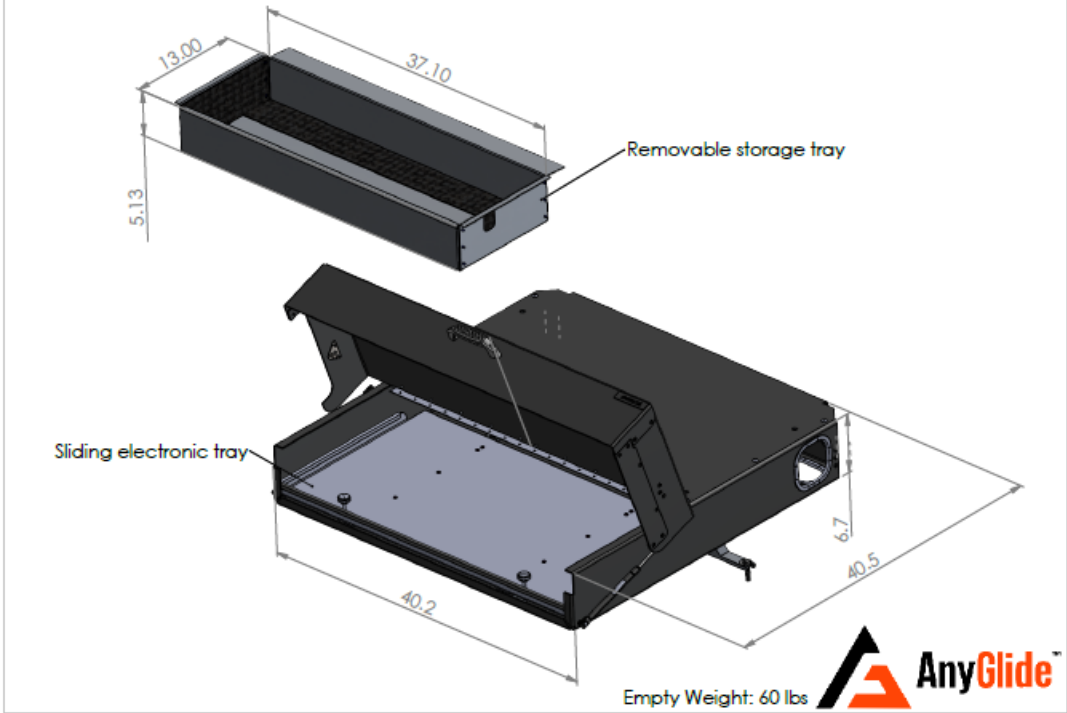

SKU 1115: Specs for AnyGlide Top Command Center

Box width 40.1"

Box length 19.9"

Box depth 17.0"

Drawer length 19.4"

Drawer width 37.6"



